

US Census Bureau Geographic Entities and Concepts

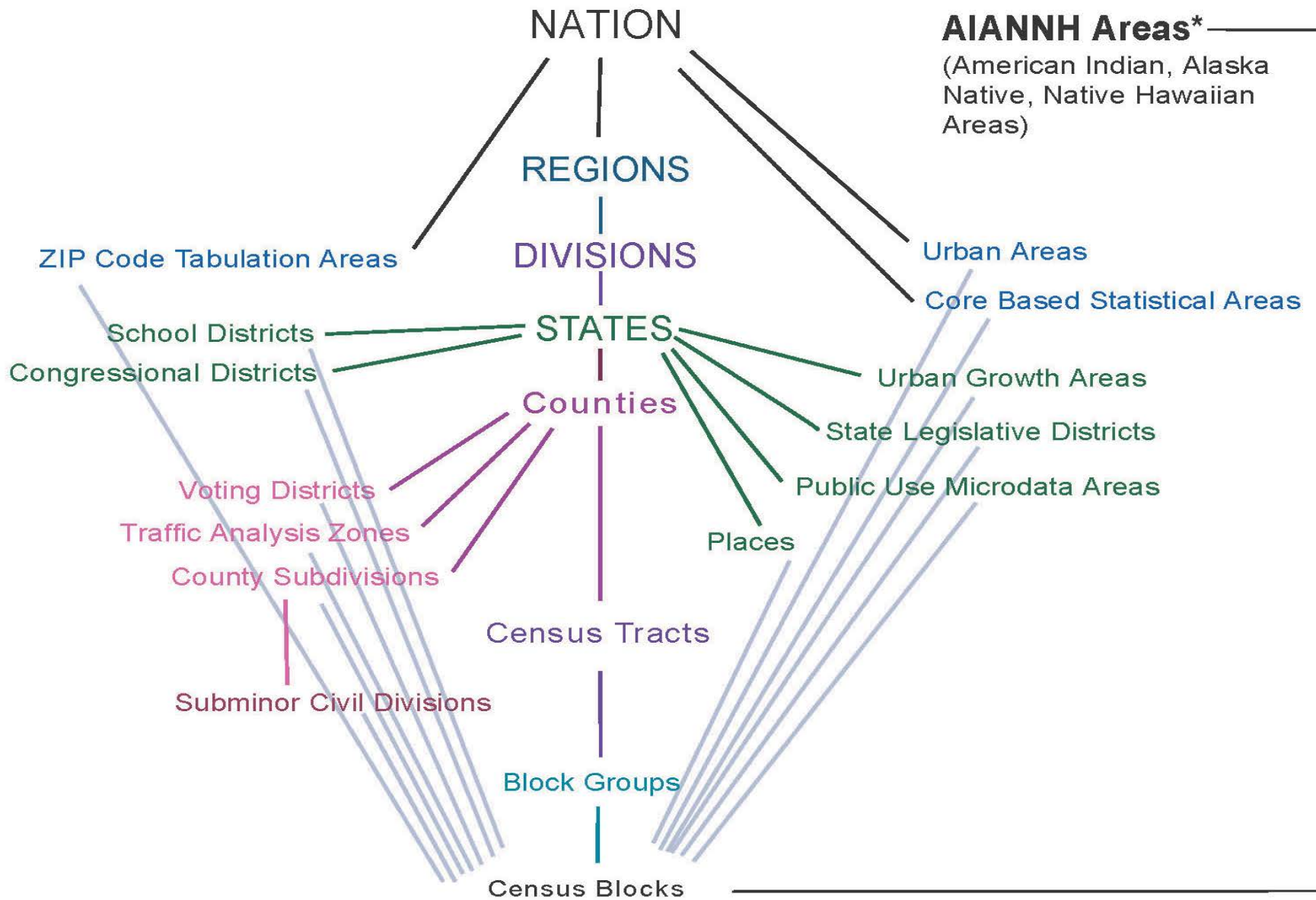

New Mexico State Data Center Annual Meeting
Albuquerque, New Mexico
November 15, 2018



Tabulation Geography

Legal

- States
- Counties
- **County subdivisions**
(Towns & townships)
- **Places** (Incorporated)
- **Tribal areas**
(Reservations and trust land)

Administrative

- Election areas
- School districts

Statistical

- Regions
- Divisions
- **County subdivisions**
(Census county divisions)
- **Places** (Census designated)
- **Tribal areas** (Statistical areas)
- **Census tracts**
- **Block groups**
- **Tabulation blocks**
- **Metropolitan/Micropolitan areas**
- **Urban areas**
- **ZCTAs**

Small Geographic Areas

Blocks

- Smallest units for 100% data tabulation (Census)
- Cover entire nation

Block Groups

- Smallest units for tabulation of sample data (surveys)
- Population ranges from 600 to 3,000
- Nest within census tracts

Census Tracts

- Small, relatively permanent, consistent statistical subdivisions of a county
- Size: optimally 4,000 people; range between 1,200 and 8,000

Geographic Area Relationships— Small Statistical Areas

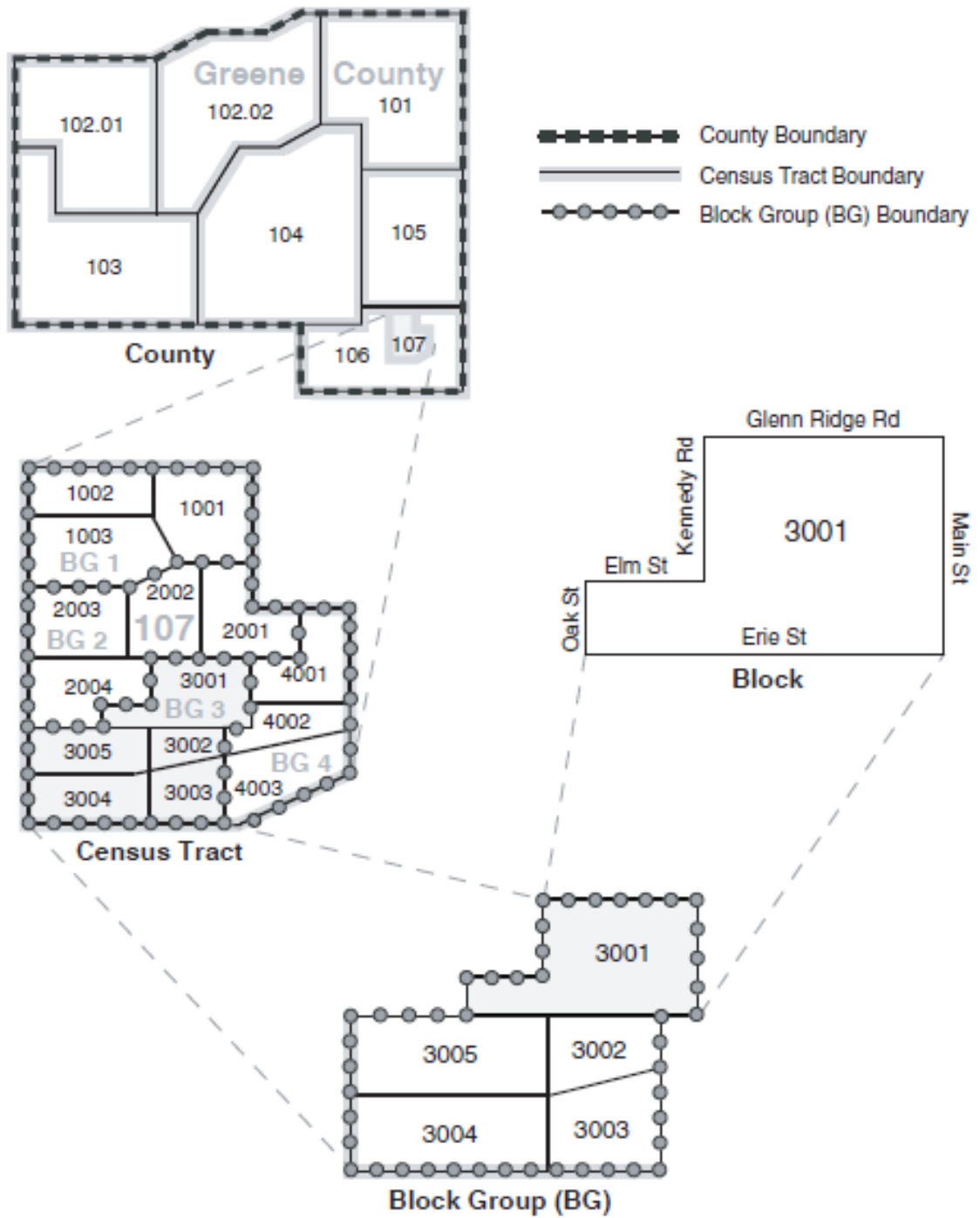

Places

Incorporated Places

- Legally bounded entity
- Referred to as cities, boroughs, towns, or villages, depending on the state
- Some form of local governance (city council, mayor, etc) recognized by the state
- Boundaries maintained through annual BAS program

Census Designated Places (CDPs)

- Statistical entity
- Area with a concentration of population, housing, and commercial structures identifiable by name; not within an incorporated place

Census 2010 Urban Areas

- Represent densely developed territory, the “urban footprint”
- Contain residential, commercial, and other nonresidential urban land uses.
- Cross all other geographic units within the nation
- Begin with a dense core of at least 1,000 people per square mile

Two types of Urban Areas

1. Urbanized Areas of 50,000 or more people
2. Urban Clusters of 2,500 up to 50,000 people

Census Tract 12, Block 1102

<u>Street Address</u>	<u>ZIP Code</u>
-----------------------	-----------------

1 May Road	22345
------------	--------------

12 Julian Drive	22345
-----------------	--------------

3 May Road	22345
------------	--------------

14 Julian Drive	22345
-----------------	--------------

5 Dee Lane	22346
------------	-------

Most frequently occurring ZIP Code:

22345

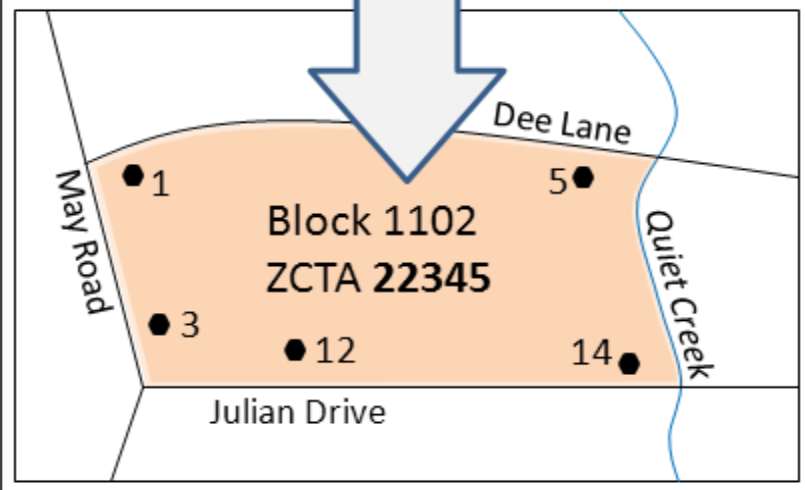

ZIP Code Tabulation Areas (ZCTAs)

- Approximate USPS ZIP Code distribution for housing units
- Represent the most frequently occurring ZIP Code within an area
- A calculated geography
- Composed of whole blocks
- ZCTAs do not nest cleanly within other geography
- 2010 ZCTAs exclude large water bodies and unpopulated areas

Current Census Bureau Tribal Geography

Legal Areas:

- Federally recognized reservations
- Federally recognized off-reservation trust lands
- Tribal Subdivisions

- **Legally defined boundaries**
- **Tribes can update these every year**

Statistical Areas:

- Tribal Tracts and Block Groups
- Tribal Designated Statistical Areas (TDSAs)
- Oklahoma Tribal Statistical Areas (OTSA)
- OTSA Tribal Subdivisions
- Census Designated Places (CDPs)

- **Boundaries defined by tribes and the Census Bureau**
- **Tribes can update these every 10 years before the census**

- Acoma Pueblo & Off-Reservation Trust Land
- Fort Sill Apache Indian Reservation
- Isleta Pueblo
- Jemez Pueblo
- Jicarilla Apache Nation Reservation & Off-Reservation Trust Land
- Laguna Pueblo & Off-Reservation Trust Land
- Mescalero Reservation
- Nambe Pueblo & Off-Reservation Trust Land
- Navajo Nation Reservation & Off-Reservation Trust Land
- Ohkay Owingeh
- Picuris Pueblo
- Pojoaque Off-Reservation Trust Land
- Pueblo de Cochiti
- Pueblo of Pojoaque
- San Felipe Pueblo
- San Felipe Pueblo/Santa Ana Pueblo joint-use area
- San Felipe Pueblo/Santo Domingo Pueblo joint-use area
- San Ildefonso Pueblo & Off-Reservation Trust Land
- Sandia Pueblo
- Santa Ana Pueblo
- Santa Clara Pueblo & Off-Reservation Trust Land
- Santo Domingo Pueblo
- Southern Ute Reservation
- Taos Pueblo & Off-Reservation Trust Land
- Tesuque Pueblo & Off-Reservation Trust Land
- Ute Mountain Reservation
- Zia Pueblo & Off-Reservation Trust Land
- Zuni Reservation & Off-Reservation Trust Land

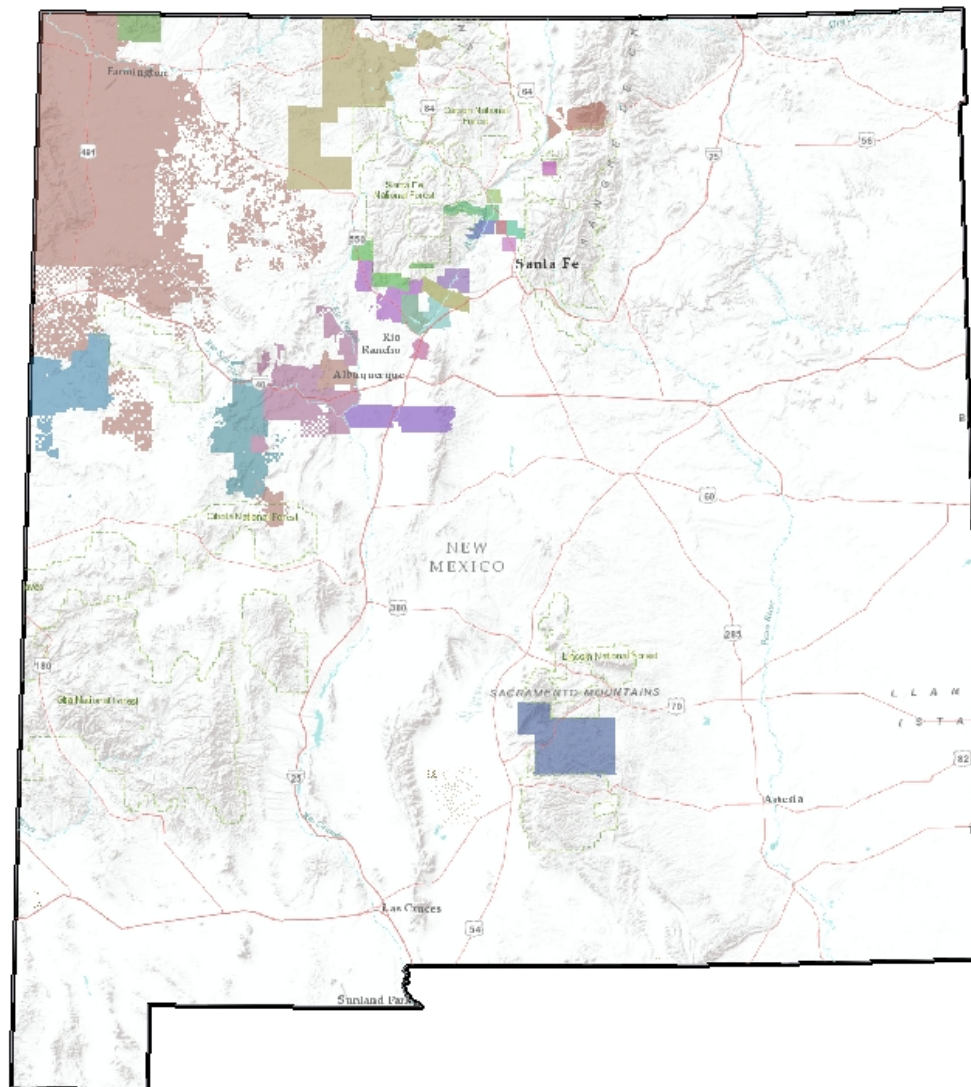

Questions? Comments?

Contact information:

Jennifer Zanoni

301-763-5647

Jennifer.zanoni@census.gov

Characteristics of Colonias

- Self-help, informal housing subdivisions.
 - Lots sold without improvements; residents build/provide their own homes.
 - Purchasing under Contract for Deed rather than traditional mortgage.
- Lacking in basic, adequate sewage disposal and water provision infrastructure.
- Lack paved roads and effective stormwater management.
- Low-income populations; high poverty.
- Predominantly Hispanic.

Challenges

- Data for specific, individual colonias gathered by researchers.
- Lack of comprehensive demographic data for colonias throughout the Border region.
- Small population size and spatial extent of most colonias meant that census tracts were often too large and contained non-colonia population. In many instances, block groups also were too large.
- Data for colonia populations were often “lost” or “hidden” within data for tract-level data.